

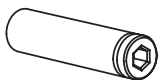

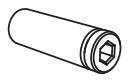

- ① x 4 
- ② x 6 
- ③ x 10 
- ④ x 1 

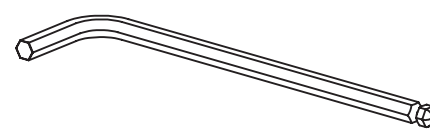
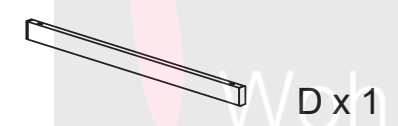
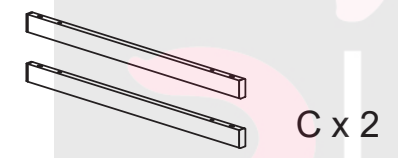
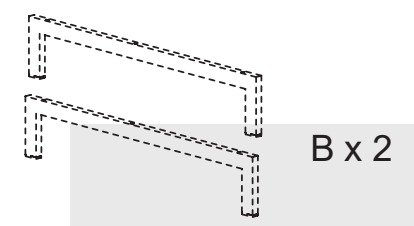
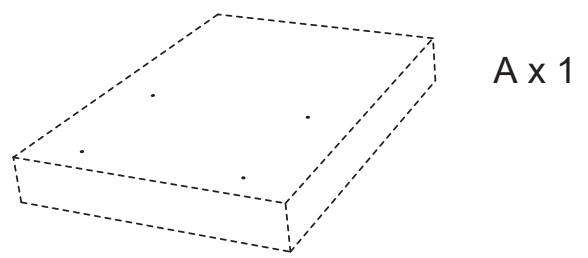

1

- ② x 2 
- ③ x 2 

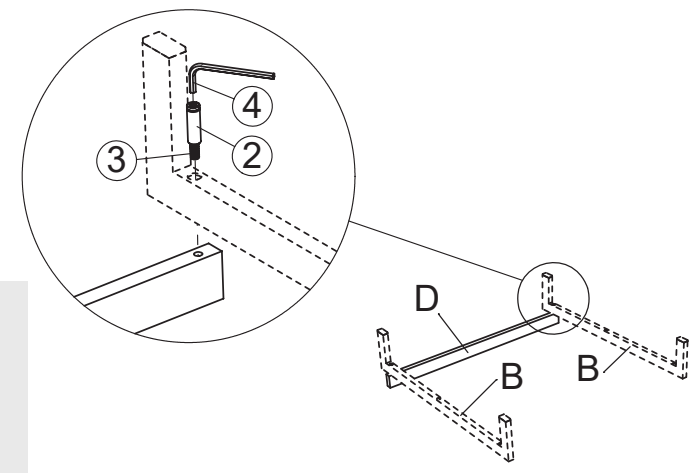

2

- ① x 4 
- ③ x 4 

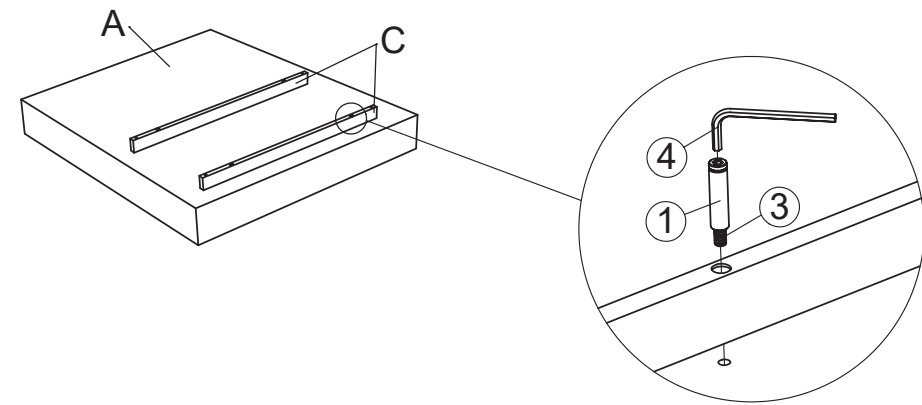

3

② x 4  ③ x 4 

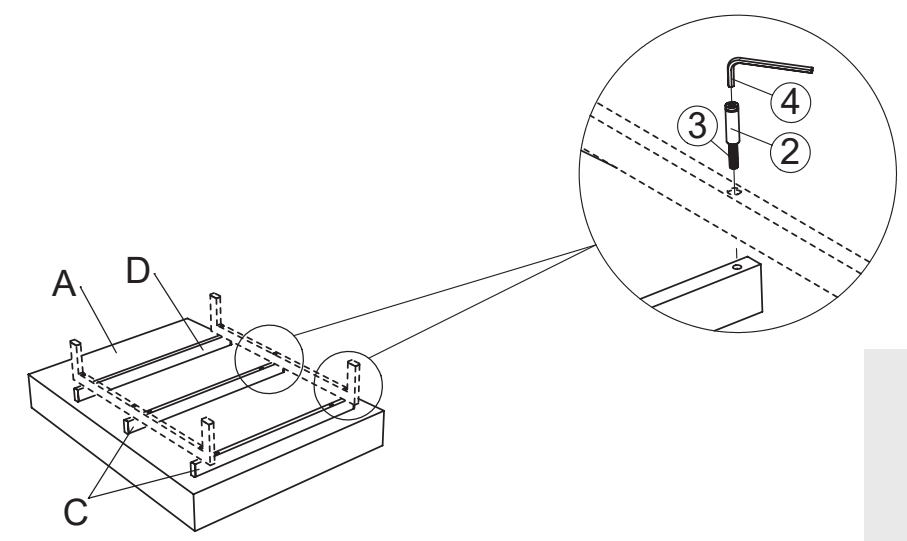

1

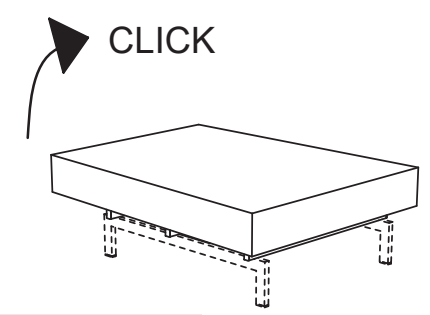

2

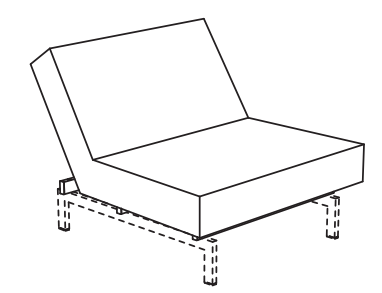

HVILE-RUHE-RELAX-REPOSER

3

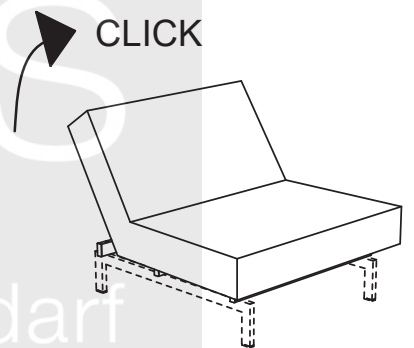

4

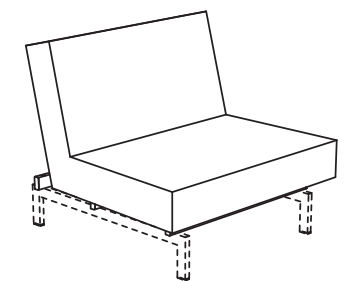

SIDDE-SITZEN-SIT-ASSISE

5

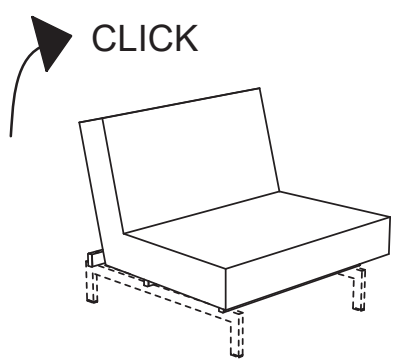

6

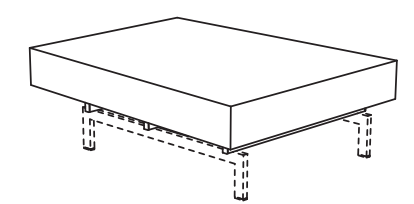

SOVE-SCHLAFEN-SLEEP-DORMIR

